

INSTALLATION INSTRUCTION

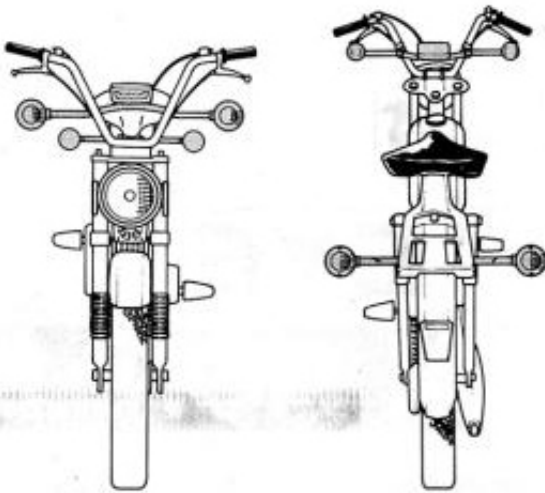

This kit is specially designed for Mopeds and contains four directional blinkers, rechargeable battery, control switch, wires and universal mounting brackets. The Nickel Cadmium battery assembled in the battery case is rechargeable and easily charged to contact with moped's magneto.

FRONT LAMP ASSEMBLY

As shown in Fig. 1, Fig. 2 attach the front lamp assembly on the handlebar of moped with the universal mounting brackets. Fasten securely with bolt and nut for permanent fit.

Attach turn signal switch to left handlebar as close to grip as possible.

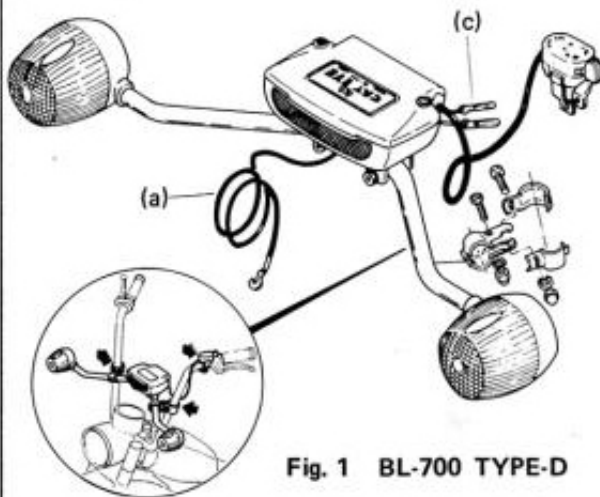

Fig. 1 BL-700 TYPE-D

SPECIFICATIONS

Battery Capacity:	6V - 8W
Discharging Capacity:	1.2 Ah
Charging Current:	Max. 1.2A
Blub:	6V - 8W (BAY 15s)
Flasher unit:	6V - 8W
Fuse:	5A
Lens:	Plastic, 2-11/16" diam., Amber

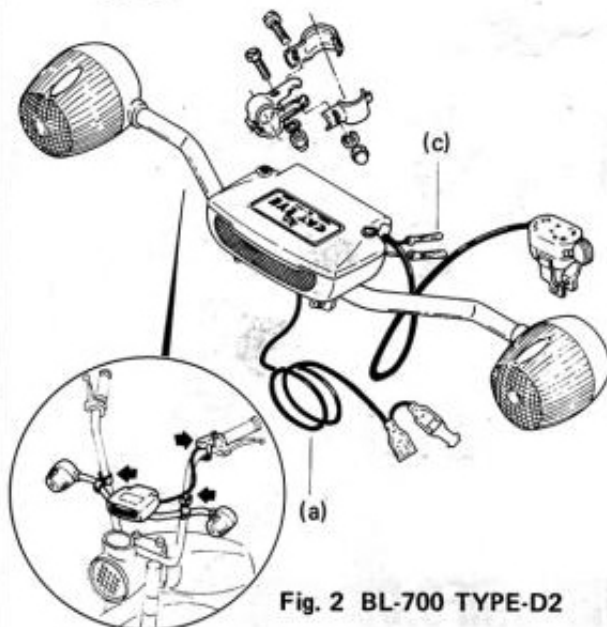
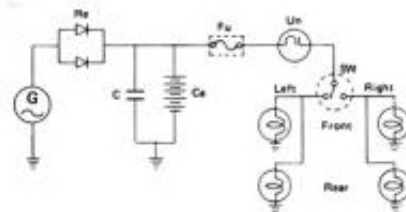

Fig. 2 BL-700 TYPE-D2

WIRING DIAGRAMS



- G : Generator
- Re : Silicon Diode
- C : Capacitor
- Ca : Nickel Cadmium Battery
- Fu : Fuse
- Un : Flasher unit
- SW : Toggle Switch

REAR LAMP ASSEMBLY

Refer to illustration of Fig. 2 to Fig. 4, attach the rear lamp assembly to desired location of moped's mudguard or rear carrier with the provided mounting brackets. Choose the best location for your particular model. Fasten securely with bolt and nut for permanent fit.

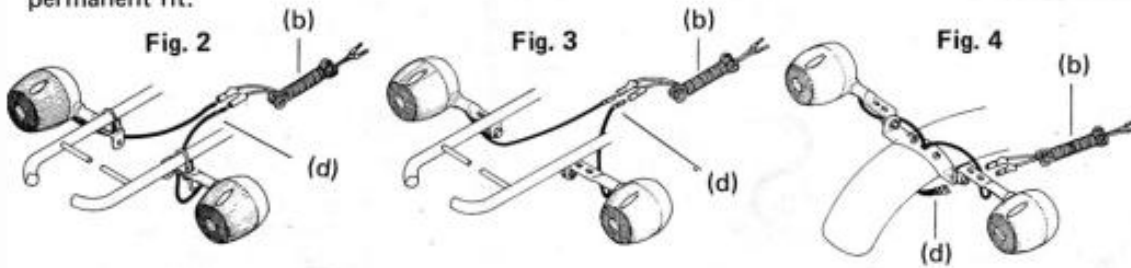

WIRING

Connect the input line wire (a) of the battery case to the output terminal of moped magneto. Refer to the wiring diagram of moped and connect the wire to one of its output terminals which supplies the most powerful current.

With the included extension wire (b), connect the output wire (c) of battery case. Then connect the rear lamp wires (d).

Take care to push the connectors completely together so that they click into place and the vinyl insulator tubing completely covers the metal connector parts. Be sure that wires do not come near the chain or exhaust system.

CHECKING

After installation, the following check is "must" before operation.

1. Check the installation and wiring if they are properly done as instructed.
2. Run the moped engine and keep it idling at least 10 minutes or more without using turn signals or lights. The battery will then have reached a satisfactory state of charge.
3. Test the system by moving the handlebar turn signal switch to "R" for right turn. Both right hand lamps should blink together. Reverse the wire connections if a left lamp works instead of right lamp. Switch to "L" for left hand turn. Both left hand lamps should operate correctly. If one of the lamps does not light, check its individual connector and bulb.

Also check for proper grounding.

In case the mudguard is made of non-conductive material such as plastic, the unit should be earthed somewhere to the metal part of moped.

CAUTIONS

1. Do not operate the device without running the engine. This may force the battery flat.
2. The battery contained in the battery case is a rechargeable Nickel Cadmium battery. The battery will be charged when engine is running. When headlamp and tail lamp are lighting, the battery might not be charged due to shortage of electrical supply from the magneto.
3. By the operation of built in self charging circuit of BL-700, the battery is charged by the moped magneto. Care should be exercised to ensure that the charge current does not exceed the overcharge capability of the battery. If the overcharge capability of the battery is exceeded, excess gas will develop and the pressure relief safety vent will relieve the excess pressure and reseal. If the excess charge current is not terminated, the vent will continue to open the reseal until the battery is nonfunctional. Be sure not to install on such motorcycles equipped with high-power magneto and engine. Otherwise, it may cause a serious damage to the power unit function.

PARTS LIST

Front Lamp Unit:

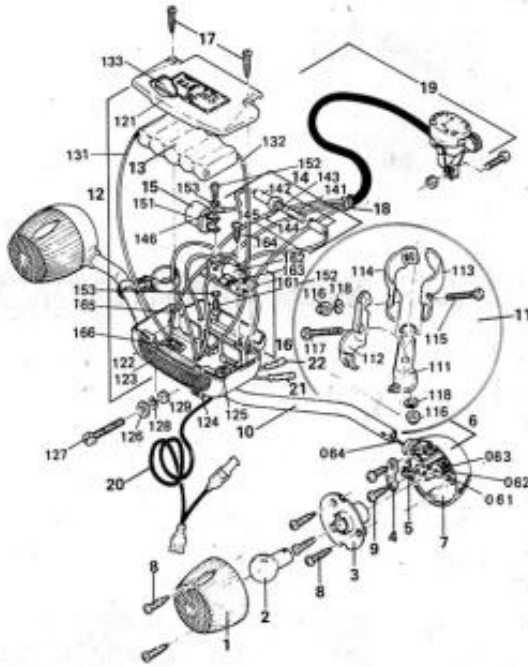

Rear Lamp Unit:

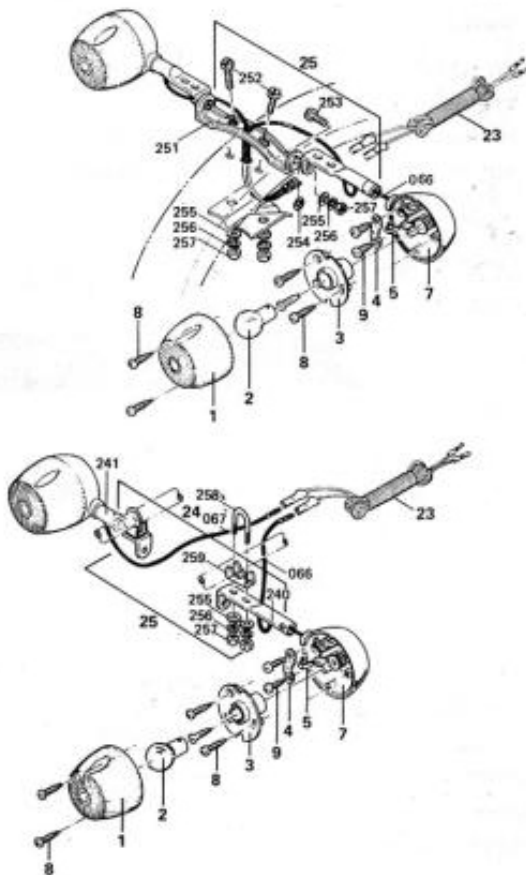

ITEM NO.	PART NO.	DESCRIPTIONS
1.	BL7-010	Plastic lens (Amber)
2.	020	Bulb. 6V-8W (BAY 15s)
3.	030	Reflective mirror.
4.	040	Fastening plate.
5.	050	Earth terminal.
6.	060	Pig tail (Terminal)
6.	061	Brass contact.
6.	062	Fiber washer.
6.	063	Spring.
6.	064	Front wire for right lamp.
6.	065	Front wire for left lamp.
6.	066	Rear wire for right lamp.
6.	067	Rear wire for left lamp.
7.	070	Lamp housing.
8.	080	Tapping screw (M3x14)
9.	090	Tapping screw (M5x12)
10.	100	Front lamp bar.
11.	110	Front universal clamp set.
11.	111	Front universal clamp (1)
11.	112	Front universal clamp (2)
11.	113	Front universal clamp (3)
11.	114	Front universal clamp (4)
11.	115	Machine screw (M5x22)
11.	116	Hex. Cap nut (M5)
11.	117	Machine screw (M5x16)
11.	118	Spring washer (M5)
12.	120	Battery case.
12.	121	Pad.
12.	122	Power unit housing.
12.	123	Front reflector.
12.	124	Lamp bar mounting plate.
12.	125	Rivet (M5x10)
12.	126	Plane washer (M5)
12.	127	Machine screw (M5x25)
12.	128	Spring washer.
12.	129	Hex. nut (M5)
13.	130	Nickel cadmium battery (5 Ply)
13.	131	Cathode wire.
13.	132	Lead wire.
13.	133	Poly Urethane pad.
14.	140	Fuse assembly.
14.	141	Fuse.
14.	142	Fuse holder.
14.	143	Fuse spring.
14.	144	Brass contact.
14.	145	Lead wire.
14.	146	Round terminal.
15.	150	Flasher (bimetal) unit.
15.	151	Flasher (bimetal)
15.	152	Machine screw (M3x6)
15.	153	Spring washer (M3)
16.	160	Commutator unit.
16.	161	Print circuit.
16.	162	Capacitor.
16.	163	Silicon Diode.
16.	164	Tapping screw (M3x8)
16.	165	Earth wire.
16.	166	Round terminal.
17.	170	Tapping screw (M3x20)
18.	180	Rubber bushing.
19.	190	Switch assembly.
20.	200	Connection wire to generator.
21.	210	Front lamp connector (right)
21.	211	Front lamp connector (left)
22.	220	Rear lamp connector (Right)
22.	221	Rear lamp connector (Left)
23.	230	Extension wire.
24.	240	Rear lamp "L" arm (Right)
24.	241	Rear lamp "L" arm (Left)
25.	250	Bridge bracket.
25.	251	Mounting adaptor.
25.	252	Machine screw (M5x18)
25.	253	Machine screw (M5x14)
25.	254	Friction washer (M5)
25.	255	Plane washer (M5)
25.	256	Spring washer.
25.	257	Hex. nut (M5)
25.	258	U bolt.
25.	259	Mounting adaptor.